

-14 NM **a semiconductor fabrication process technology.** Generally, the length of the transistor is 14nm, the space electrons move from source to drain, the foundation of a transistor.

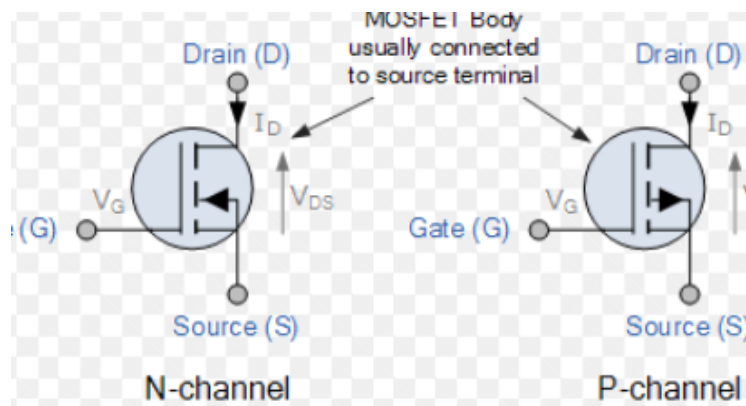

Combination Circuit (Boolean Algebra)

Law/Theorem	Law of Addition	Law of Multiplication
Identity Law	$x + 0 = x$	$x \cdot 1 = x$
Complement Law	$x + x' = 1$	$x \cdot x' = 0$
Idempotent Law	$x + x = x$	$x \cdot x = x$
Dominant Law	$x + 1 = 1$	$x \cdot 0 = 0$
Involution Law	$(x')' = x$	
Commutative Law	$x + y = y + x$	$x \cdot y = y \cdot x$
Associative Law	$x + (y + z) = (x + y) + z$	$x \cdot (y \cdot z) = (x \cdot y) \cdot z$
Distributive Law	$x \cdot (y + z) = x \cdot y + x \cdot z$	$x + y \cdot z = (x + y) \cdot (x + z)$
Demorgan's Law	$(x + y)' = x' \cdot y'$	$(x \cdot y)' = x' + y'$
Absorption Law	$x + (x \cdot y) = x$	$x \cdot (x + y) = x$

Simply the logical Expression function

$$F = AB + A(B+C) + B(B+C) \quad (\text{Distributive law})$$

$$F = AB + AB + AC + BB + BC$$

$$F = AB + AC + BB + BC \quad (3) \quad (\text{Idempotent})$$

$$F = AB + AC + BB + BC \quad (4)$$

$$F = AB + AC + B + BC \quad (5) \quad (\text{Idempotent})$$

$$F = AB + AC + B + BC \quad (6)$$

$$F = AB + AC + B \quad (7) \quad (\text{Absorption law})$$

$$F = AB + B + AC \quad (8) \quad (\text{Distributive law})$$

$$F = B + AC \quad (9) \quad (\text{Absorption})$$

Floating point conversion Design

Biased Exponent		Exponent		Unsigned Fraction	Meaning
Decimal	Binary	Bias = 7	Bias = 8		
0	0000	0	0	0	Represents FP number zero (0.0)
0	0000			≠ 0	Represents a very small FP number called denormal, not typically stored in memory
15	1111			0	Represents infinity (e.g., the result of 1.0 divided by 0.0)
15	1111			≠ 0	Represents an invalid FP number (e.g., the result of computing $\sqrt{-1}$),
1-14	0001-1110	-6 to 7	-7 to 6	Any	Represents a normal FP number

TABLE 1.3 4-Bit Biased Exponent versus Exponent

- **Convert 5.375 Decimal to Floating point representation**
 - See video notes.